

HONDA
POWER PRODUCTS

GENERATOR EU10i



ECOLOGY CONSCIOUS TECHNOLOGY

OWNER'S MANUAL

Honda EU10i

OWNER'S MANUAL



ECOLOGY CONSCIOUS TECHNOLOGY

The "e-SPEC" mark symbolizes environmentally responsible technologies applied to Honda power equipment, which contains our wish to "preserve nature for generations to come."

Thank you for purchasing a Honda generator.

This manual covers operation and maintenance of the EU10i generator.

All information in this publication is based on the latest product information available at the time of approval for printing.

Honda Motor Co., Ltd. reserves the right to make changes at any time without notice and without incurring any obligation.

No part of this publication may be reproduced without written permission.

This manual should be considered a permanent part of the generator and should remain with it if it is resold.

Pay special attention to statements preceded by the following words:

▲WARNING Indicates a strong possibility of severe personal injury or death if instructions are not followed.

CAUTION: Indicates a possibility of personal injury or equipment damage if instructions are not followed.

NOTE: Gives helpful information.

If a problem should arise, or if you have any questions about the generator, consult an authorized Honda dealer.

▲WARNING

Honda generator is designed to give safe and dependable service if operated according to instructions. Read and understand the Owner's Manual before operating the generator. Failure to do so could result in personal injury or equipment damage.

- The illustration may vary according to the type.

CONTENTS

1. SAFETY INSTRUCTIONS.....	3
2. SAFETY LABEL LOCATIONS.....	6
CE mark and noise label locations.....	8
3. COMPONENT IDENTIFICATION.....	9
4. PRE-OPERATION CHECK.....	13
5. STARTING THE ENGINE.....	18
• Carburetor Modification for High Altitude Operation	
6. GENERATOR USE.....	22
7. STOPPING THE ENGINE.....	34
8. MAINTENANCE.....	36
9. TRANSPORTING/STORAGE.....	43
10. TROUBLESHOOTING.....	45
11. SPECIFICATIONS.....	47
12. WIRING DIAGRAM.....	49
13. MAJOR Honda DISTRIBUTOR ADDRESSES.....	54

1. SAFETY INSTRUCTIONS

▲WARNING

To ensure safe operation –



- Honda generator is designed to give safe and dependable service if operated according to instructions. Read and understand the Owner's Manual before operating the generator. Failure to do so could result in personal injury or equipment damage.

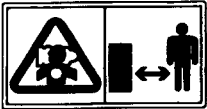

- Exhaust gas contains poisonous carbon monoxide. Never run the generator in an enclosed area. Be sure to provide adequate ventilation. When installed inside, adequate ventilation should be provided.



- The muffler becomes very hot during operation and remains hot for a while after stopping the engine. Be careful not to touch the muffler while it is hot. Let the engine cool before storing the generator indoors.
- The engine exhaust system will be heated during operation and remain hot immediately after stopping the engine. To prevent scalding, pay attention to the warning marks attached to the generator.

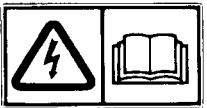

- Never connect a cable other than the special cable for parallel operation to the parallel operation socket. Electric shocks can result if this instruction is not followed.

▲WARNING

To ensure safe operation —



- | | |
|---|--|
| <p>Ⓐ STOP THE ENGINE BEFORE REFUELING. BE SURE TO CONNECT ONLY THE SPECIAL LEAD TO THE PARALLEL OPERATION RECEPTACLE.</p> <p>ⓕ ARRÊTEZ LE MOTEUR AVANT DE REFAIRE LE PLEIN. CONNECTER UNOQUEMENT LE CORDON SPECIAL A LA PRISE D'UTILISATION EN PARALLELE.</p> <p>ⓓ VOR AUFTANKEN MOTOR ABSTELLEN. VERBINDEN SIE AUSSCHLIEßLICH DIE SPEZIALKABEL MIT DEN STECKDOSEN FÜR PARALLELBETRIEB.</p> <p>Ⓛ ARRESTARE IL MOTORE PRIMA DI FARE RIFORNIMENTO. ASSICURARSI DI COLLEGARE SOLTANTO IL CAVO SPECIALE ALLA PRESA PER FUNZIONAMENTO PARALLELO.</p> <p>Ⓜ STOP DE MOTOR ALVORENS BIJ TE TANKEN. SLUIT ALLEEN HET SPECIALE SMOER AAN OP DE AANSLUITING VOOR PARALLEL BEDRIJF.</p> <p>Ⓔ PARE EL MOTOR ANTES DE REPOSTAR. ASEGURESE DE QUE SOLO CONECTA EL CABLE ESPECIAL EN EL CONECTOR DE OPERACION PARALELA.</p> | <p>Ⓟ DESLIGUE O MOTOR ANTES DE ABASTECER. LIGUE SÓ A EXTENSÃO ESPECIAL A TOMADA DE USO EM PARALELO.</p> <p>Ⓢ ἸΣΤΑΜΑΤΕ ΤΟ ΜΟΤΩΡ ΠΡΙΝ ΤΟΝ ΑΝΕΠΙΧΑΙΤΩ ΜΕ ΚΑΥΣΙΜΑ. ΒΕΒΑΙΩΘΕΙΤΕ ΟΤΙ ΘΑ ΣΤΗΛΕΞΕΤΕ ΜΟΝΩΝ ΤΟ ΕΙΔΙΚΟ ΚΑΒΛΟ ΣΤΗΝ ΥΠΟΔΟΧΗ ΠΑΡΑΛΛΗΛΗΣ ΧΡΗΣΗΣ.</p> <p>Ⓢ ΣΤΑΝΓ ΑΥ ΜΟΤΩΡΝ ΦΟΡΕ ΒΡΑΝΣΛΕΠΑΨΥΛΛΙΝΓ. ΑΝΒΑΝΔ ΕΝΔΑΣ ΣΠΕΚΙΑΛΣΛΑΔΔ ΦΟΡ ΑΝΣΛΥΤΝΙΝΓ ΤΙΛΛ ΠΑΡΑΛΕΛΛ ሀΤΤΑΓΕΤ.</p> <p>Ⓜ STOP MOTOREN FØR BRÆNDSTOFFPÆYLDNING. TILSLUT ALTID KUN SPECIALLEDNINGEN I PARALLELSTIKKENE.</p> <p>Ⓜ ΣΛÅ ΑΥ ΜΟΤΟΡΕΝ ΦØR ΠÆΨΥΛΛΙΝΓ. ΒΡΥΚ ΚΥΝ ΣΠΕΚΙΑΛΕΔΝΙΝΓ ΤΙΛ ΠΑΡΑΛΕΛ ΣΤΙΚΚΟΝΑΚΤ.</p> <p>Ⓢ ΣΑΜΜΥΤΑ ΜΟΟΤΩΡΝ ΕΝΝΕΝ ΤΑΝΚΚΑΥΣΤΑ. ΒΑΡΜΙΣΤΥ ΕΤΤÅ ΑΜΝΟΑΣΤΑΑΝ ΕΡΙΚΟΨ.ΛΟΗΤΟΣΑΡΛΑ ΟΝ ΚΥΤΚΕΤΤΥ ΠΙΣΤΟΚΑΣΙΩΗΝ ΡΙΝΝΑΚΚΑΨΥΛΤΤΟÅ ΒΑΡΤΕΝ.</p> |
|---|--|

- Gasoline is extremely flammable and explosive under certain conditions. Refuel in a well ventilated area with the engine stopped.
- Keep away from cigarette, smoke and sparks when refueling the generator. Always refuel in a well-ventilated location.
- Wipe up spilled gasoline at once.



- Connections for standby power to a building's electrical system must be made by a qualified electrician and must comply with all applicable laws and electrical codes. Improper connections can allow electrical current from the generator to back feed into the utility lines. Such back feed may electrocute utility company workers or others who contact the lines during a power outage, and when utility power is restored, the generator may explode, burn, or cause fires in the building's electrical system.

▲WARNING

To ensure safe operation —

- Always make a pre-operation inspection (page 13) before you start the engine. You may prevent an accident or equipment damage.
- Place the generator at least 1 m (3 ft) away from buildings or other equipment during operation.
- Operate the generator on a level surface.
If the generator is tilted, fuel spillage may result.
- Know how to stop the generator quickly and understand operation of all the controls. Never permit anyone to operate the generator without proper instructions.
- Keep children and pets away from the generator when it is in operation.
- Keep away from rotating parts while the generator is running.
- The generator is a potential source of electrical shocks when misused; do not operate with wet hands.
- Do not operate the generator in rain or snow and do not let it get wet.

2. SAFETY LABEL LOCATIONS

These labels warn you of potential hazards that can cause serious injury. Read the labels and safety notes and precautions described in this manual carefully.

If a label comes off or becomes hard to read, contact your Honda dealer for a replacement.

[For European model: G, GW, B, F, W types]

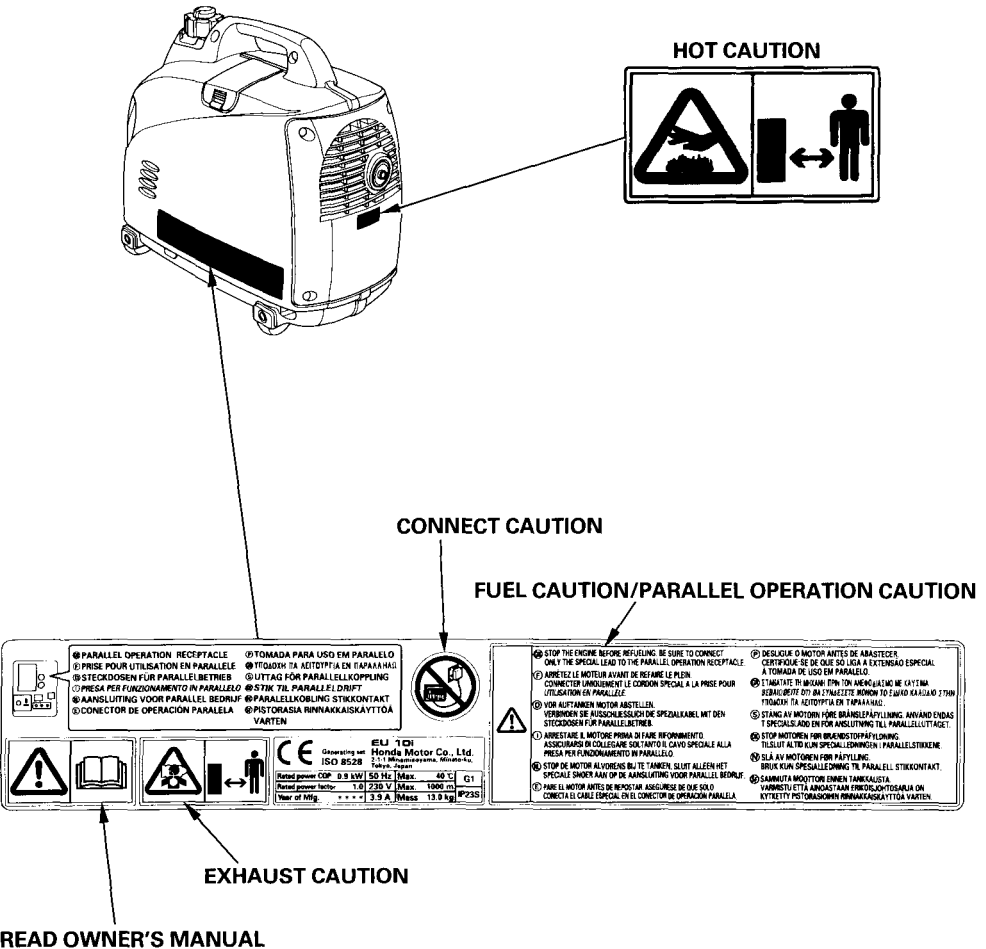

SOCKET CAUTION

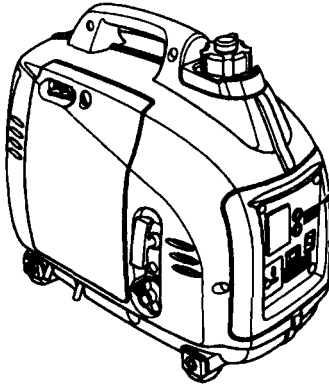
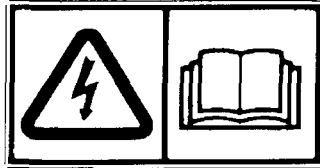

[For Australian model: U type]

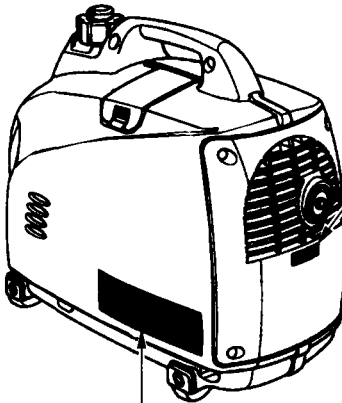

<p>CAUTION</p> <ul style="list-style-type: none"> DO NOT USE GENERATOR FOR TO BURNER OF CARBON MONOXIDE POISONING. DO NOT CONNECT THE OUTLET OF THIS GENERATOR TO HOUSE WIRING. STOP THE ENGINE BEFORE REFUELLING. CHECK FOR SPILLAGE FUEL OR FUEL LEAKS. DO NOT FILL THE FUEL TANK BEYOND THE UPPER LIMIT LINE. FOR RETAILER REPARATION, READ THE OWNER'S MANUAL. UNDER OTHER OR IN TRAVEL, MAKE SURE THAT THE FUSE SWITCH AND THE FUEL TANK CAP COVER ARE IN "OFF" POSITION TO PREVENT FUEL LEAKS. BE SURE TO CONNECT ONLY THE SPREAD LEAD TO THE PARALLEL ORIENTATION RECEPTACLE. 		<p>ATTENTION</p> <ul style="list-style-type: none"> NE PAS UTILISER DANS UN LOCAL CLÔS OU LES VAPEURS NOCIVES DE MONOXYDE DE CARBONE PEUVENT S'ACCUMULER. NE JAMAIS CONNECTER LE CÂBLE D'ÉLECTRICITÉ À UNE PRISE DE MOTEUR. ARRÊTER LE MOTEUR AVANT DE FAIRE LE PLEIN D'ÉNERGIE. CONTRÔLER QU'IL N'Y A NI FUIE D'ÉNERGIE, NI D'ÉCHAPPEMENT-CHAUD SUR L'APPAREIL. NE PAS REMPLIR LE RÉSERVOIR D'ÉNERGIE AU DESSUS DU NIVEAU MAXIMUM. POUR PLUS D'INFORMATION, LIRE LE MANUEL DE L'UTILISATEUR. QUAND LE MOTEUR ÉLECTRIQUE EST ARRÊTÉ OU TRANSPORTÉ, ASSUREZ-VOUS QUE LE CONTACT D'ARRÊT DU MOTEUR ET LA MISE À L'ARRÊT DU RÉSERVOIR D'ÉNERGIE SONT SUR LA POSITION "OFF" APRÈS ÉVITER TOUTE FUIE D'ÉNERGIE. CONNECTER UNiquement LE CORDON SPÉCIAL À LA PRISE D'UTILISATION EN PARALLÈLE. 																															
<p>EU 10</p> <table border="1"> <tr> <td>A C</td> <td>VOLTAGE</td> <td>240V</td> <td>D C</td> <td>VOLTAGE</td> <td>12V</td> </tr> <tr> <td></td> <td>FREQUENCY</td> <td>50Hz</td> <td></td> <td>CURRENT</td> <td>5A</td> </tr> <tr> <td></td> <td>RATED OUTPUT</td> <td>1000VA</td> <td>FUEL</td> <td colspan="2">GASOLINE(PETROL)</td> </tr> <tr> <td></td> <td>MAX. OUTPUT</td> <td>1600VA</td> <td>CARBURANT</td> <td colspan="2">ÉNERGIE</td> </tr> <tr> <td></td> <td>PHASE</td> <td>1Ø</td> <td></td> <td></td> <td></td> </tr> </table>		A C	VOLTAGE	240V	D C	VOLTAGE	12V		FREQUENCY	50Hz		CURRENT	5A		RATED OUTPUT	1000VA	FUEL	GASOLINE(PETROL)			MAX. OUTPUT	1600VA	CARBURANT	ÉNERGIE			PHASE	1Ø				<p>ACN 006 662 862</p>	
A C	VOLTAGE	240V	D C	VOLTAGE	12V																												
	FREQUENCY	50Hz		CURRENT	5A																												
	RATED OUTPUT	1000VA	FUEL	GASOLINE(PETROL)																													
	MAX. OUTPUT	1600VA	CARBURANT	ÉNERGIE																													
	PHASE	1Ø																															

• CE mark and noise label locations

[For European model: G, GW, B, F, W types]

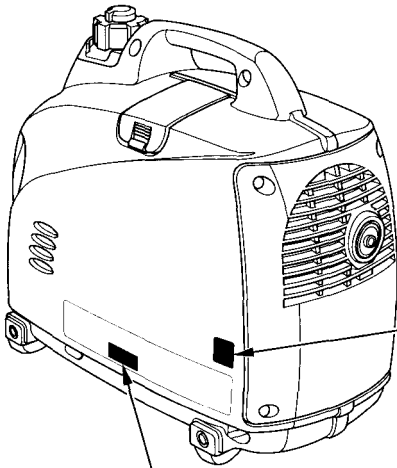

NOISE LABEL

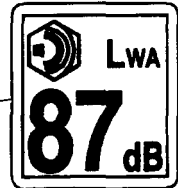

• CE MARK

CE	Generating set		EU 10i		Manufacturer and address	
	ISO 8528		Honda Motor Co., Ltd.		Maximum ambient temperature	
			2-1-1 Minamiaoyama, Minato-ku Tokyo, Japan			
Rated power COP	0.9 kW	50 Hz	Max.	40 °C	G1	Performance class
Rated power factor	1.0	230 V	Max.	1000 m		IP23S
Year of Mfg.	***	3.9 A	Mass	13.0 kg		

Maximum altitude Dry weight

3. COMPONENT IDENTIFICATION

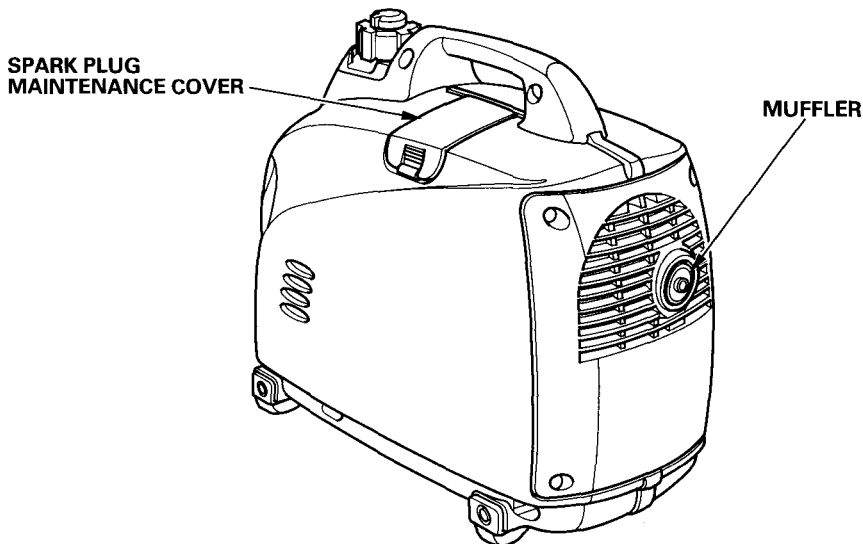
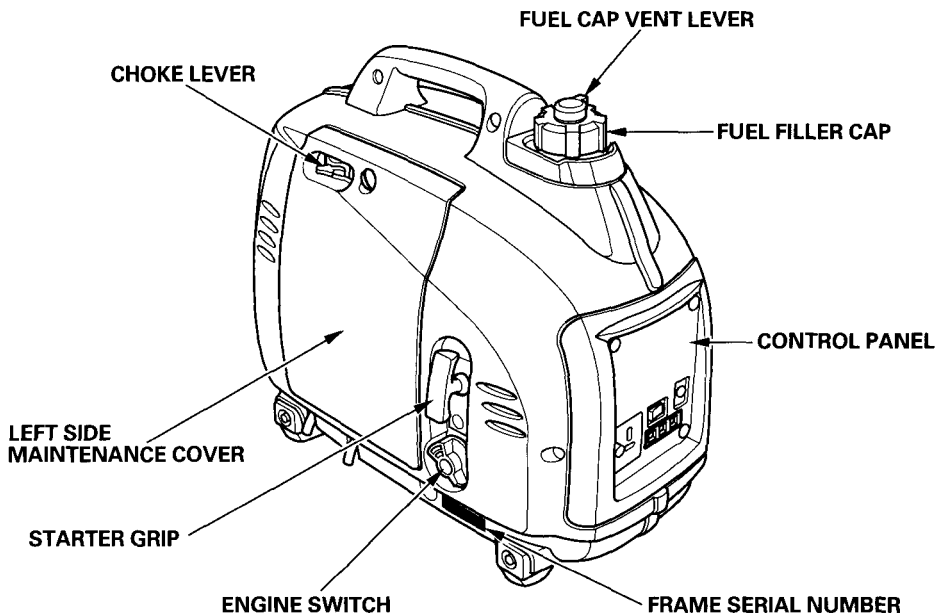

Record the frame serial number in the space below. You will need this serial number when ordering parts.

Frame serial number: _____

CONTROL PANEL

G, GW, F, W types

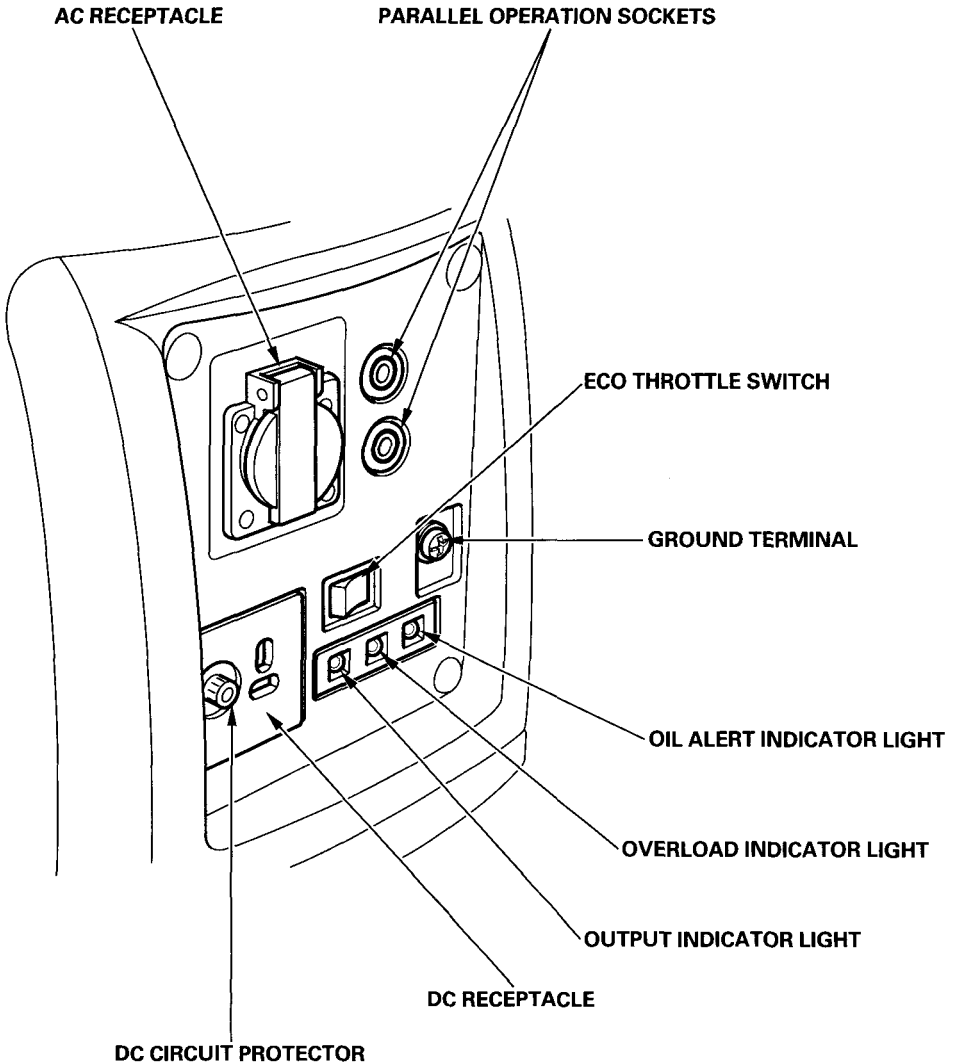

B type

AC RECEPTACLE

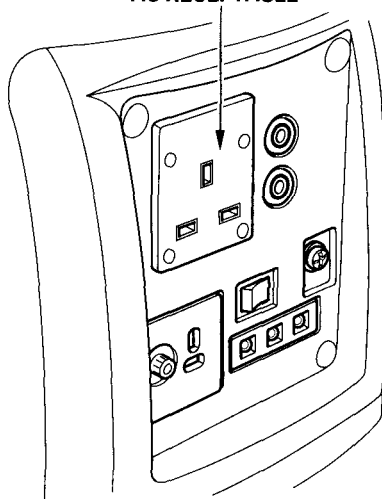

U type

AC RECEPTACLE

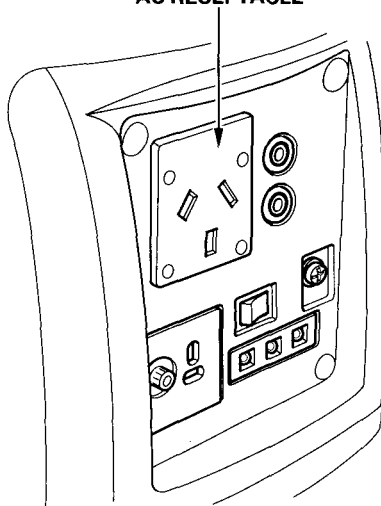

Eco Throttle

ECO:

Engine speed is kept at idle automatically when the electrical appliance is disconnected and it returns to the proper speed by the electrical load when electrical appliance is connected. This position is recommended to minimize the fuel consumption while in operation.

NOTE:

- Eco Throttle system does not operate sufficiently if the electrical appliance requires the momentary electric power.
- When high electrical load appliances is connected simultaneously, turn the Eco Throttle switch to the OFF position to reduce voltage changes.
- In DC operation, turn the eco throttle switch to the OFF position.

OFF:

Eco Throttle system does not operate. Engine speed is kept over rated speed.

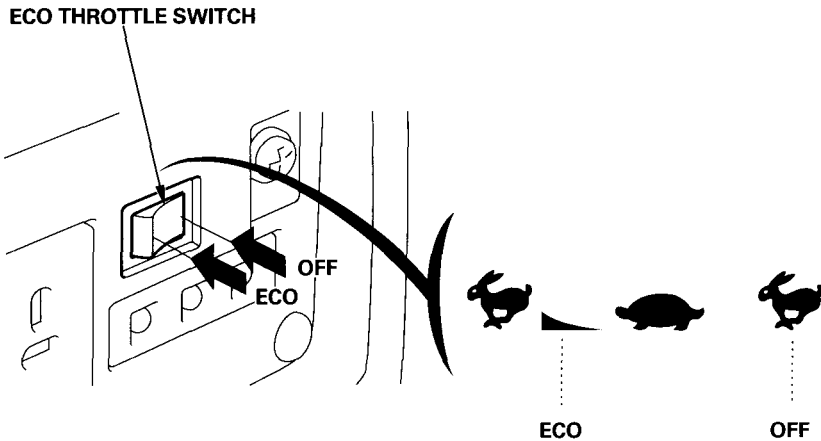

4. PRE-OPERATION CHECK

CAUTION:

Be sure to check the generator on a level surface with the engine stopped.

1. Check the engine oil level.

CAUTION:

Using nondetergent oil or 2-stroke engine oil could shorten the engine's service life.

Use high-detergent, premium quality 4-stroke engine oil, certified to meet or exceed U.S. automobile manufacturer's requirements for API Service Classification SG, SF.

Select the appropriate viscosity for the average temperature in your area.

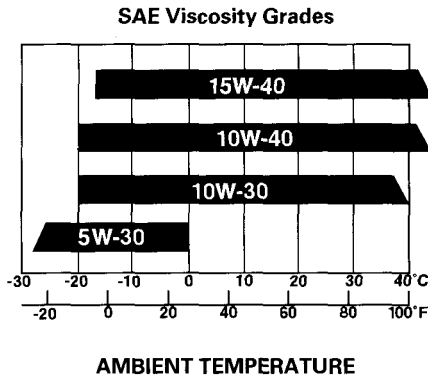

Loosen the cover screw and remove the left side maintenance cover. (see page 37)

Remove the oil filler cap, and wipe the dipstick with a clean rag. Check the oil level by inserting the dipstick in the filler hole without screwing it in.

If the oil level is below the end of the dipstick, refill with recommended oil up to the top of the oil filler neck.

CAUTION:

Running the engine with insufficient oil can cause serious engine damage.

NOTE:

The Oil Alert System will automatically stop the engine before the oil level falls below the safe limit. However, to avoid the inconvenience of an unexpected shutdown, it is still advisable to visually inspect the oil level regularly.

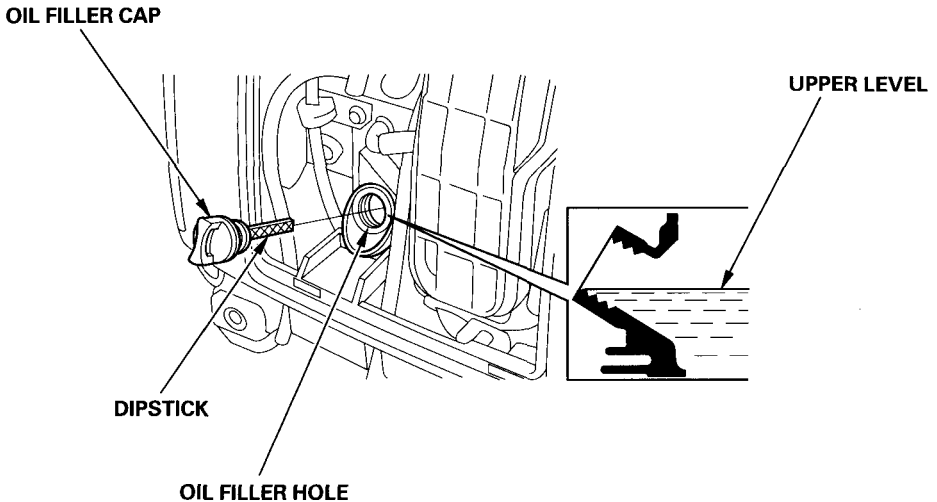

2. Check the fuel level.

If the fuel level is low, refuel the fuel tank until the level as specified. After refueling, tighten the fuel filler cap securely.

Use automotive unleaded gasoline with a Research Octane Number of 91 or higher (a Pump Octane Number of 86 or higher). Never use stale or contaminated gasoline or an oil/gasoline mixture. Avoid getting dirt or water in the fuel tank.

▲WARNING

- Gasoline is extremely flammable and is explosive under certain conditions.
- Refuel in a well-ventilated area with the engine stopped. Do not smoke or allow flames or sparks in the area where the engine is refueled or where gasoline is stored.
- Do not overfill the fuel tank (there should be no fuel above the upper limit mark). After refueling, make sure the fuel filler cap is closed properly and securely.
- Be careful not to spill fuel when refueling. Spilled fuel or fuel vapor may ignite. If any fuel is spilled, make sure the area is dry before starting the engine.
- Avoid repeated or prolonged contact with skin or breathing of vapor.

KEEP OUT OF REACH OF CHILDREN.

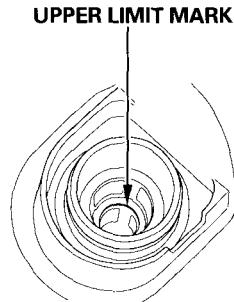
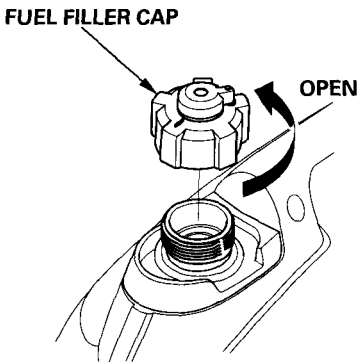

NOTE:

Gasoline spoils very quickly depending on factors such as light exposure, temperature and time.

In worst cases, gasoline can be contaminated within 1 month.

Using contaminated gasoline can seriously damage the engine (carburetor clogged, valve stuck).

Such damage due to spoiled fuel is disallowed from coverage by the warranty.

To avoid this please strictly follow these recommendations:

- Only use specified gasoline.
- To slow deterioration, keep gasoline in a certified fuel container.
- If long storage (more than 1 month) is foreseen, drain fuel tank and carburetor (page 43).

Gasolines containing alcohol

If you decide to use a gasoline containing alcohol (gasohol), be sure its octane rating is at least as high as that recommended by Honda. There are two types of "gasohol": one containing ethanol, and the other containing methanol.

Do not use gasohol that contains more than 10% ethanol. Do not use gasoline containing methanol (methyl or wood alcohol) that does not also contain cosolvents and corrosion inhibitors for methanol. Never use gasoline containing more than 5% methanol, even if it has cosolvents and corrosion inhibitors.

NOTE:

- Fuel system damage or engine performance problems resulting from the use of fuels that contain alcohol is not covered under the warranty.

Honda cannot endorse the use of fuels containing methanol since evidence of their suitability is as yet incomplete.

- Before buying fuel from an unfamiliar station, try to find out if the fuel contains alcohol, if it does, confirm the type and percentage of alcohol used.

If you notice any undesirable operating symptoms while using a gasoline that contains alcohol, or one that you think contains alcohol, switch to a gasoline that you know does not contain alcohol.

3. Check the air cleaner.

Check the air cleaner element to be sure it is clean and in good condition.

Loosen the cover screw and remove the left side maintenance cover. Press the latch tab on the top of the air cleaner body, remove the air cleaner cover, check the element.

Clean or replace the element if necessary. (see page 38).

CAUTION:

Never run the engine without the air cleaner element. Rapid engine wear will result from contaminants, such as dust and dirt, being drawn through the carburetor, into the engine.

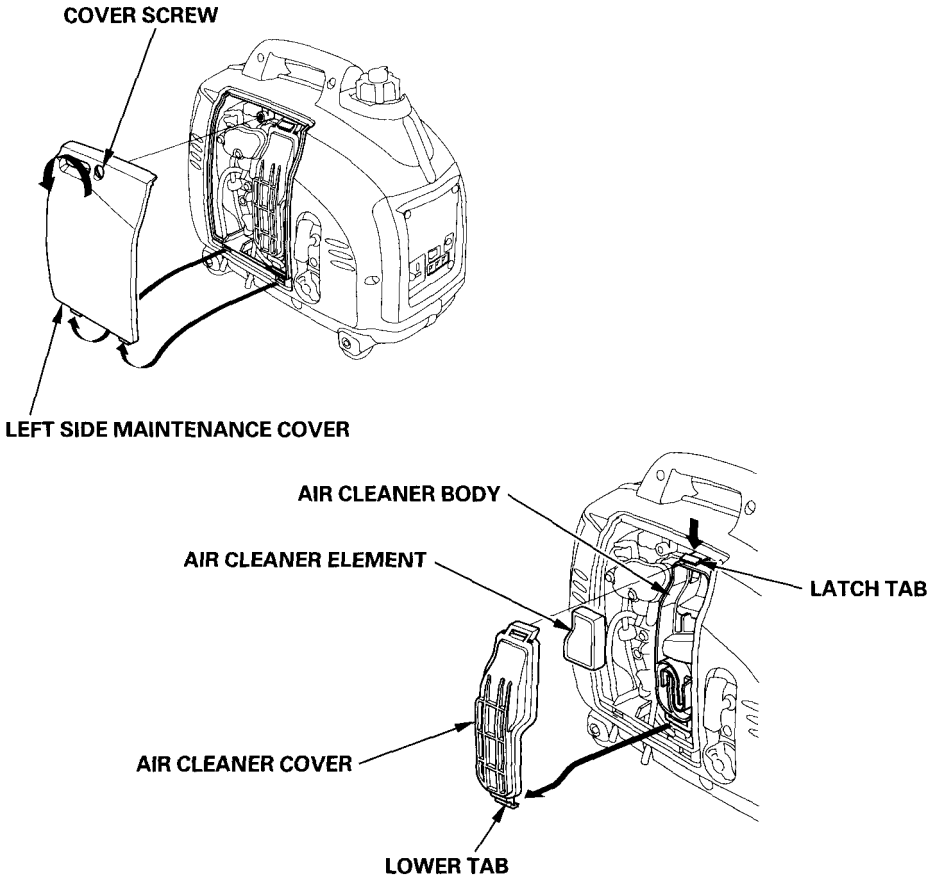

5. STARTING THE ENGINE

Before starting the engine disconnect any load from the AC receptacle.

1. Turn the fuel cap lever fully clockwise to the ON position.

NOTE:

Turn the fuel cap vent lever to the OFF position when transporting the generator.

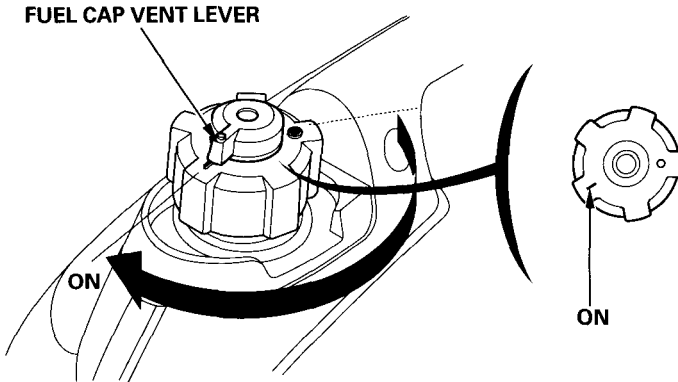

2. Turn the engine switch to the ON position.

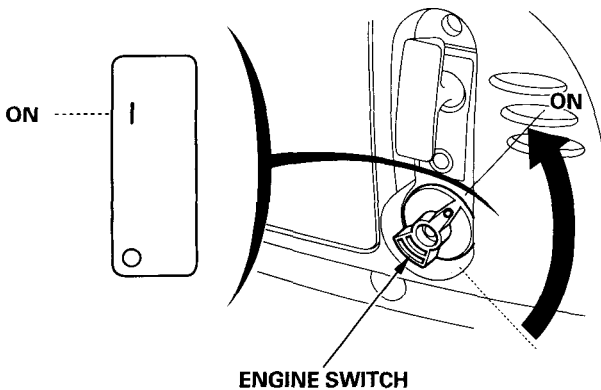

3. Move the choke lever to the CLOSED position.

NOTE:

- Do not use the choke when the engine is warm or the air temperature is high.

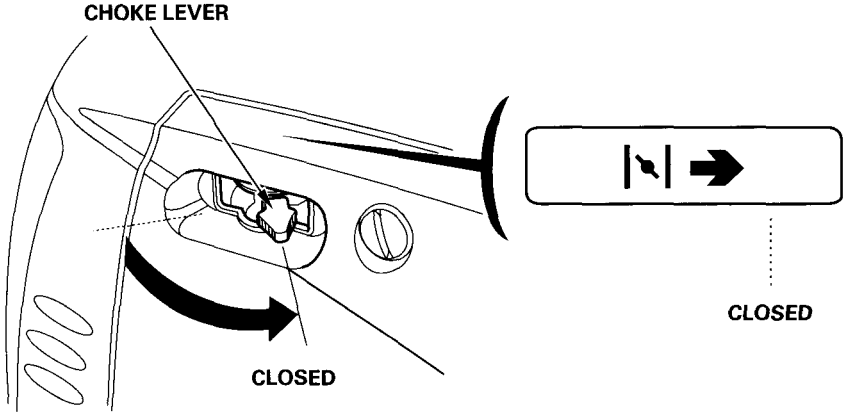

4. Pull the starter grip lightly until you feel resistance, then pull the starter grip briskly toward the arrow as shown below.

CAUTION:

Do not allow the starter grip to snap back. Return it slowly by hand.

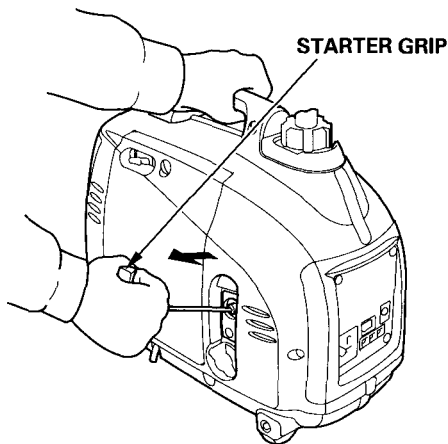

5. Move the choke lever to the OPEN position as the engine warms up.

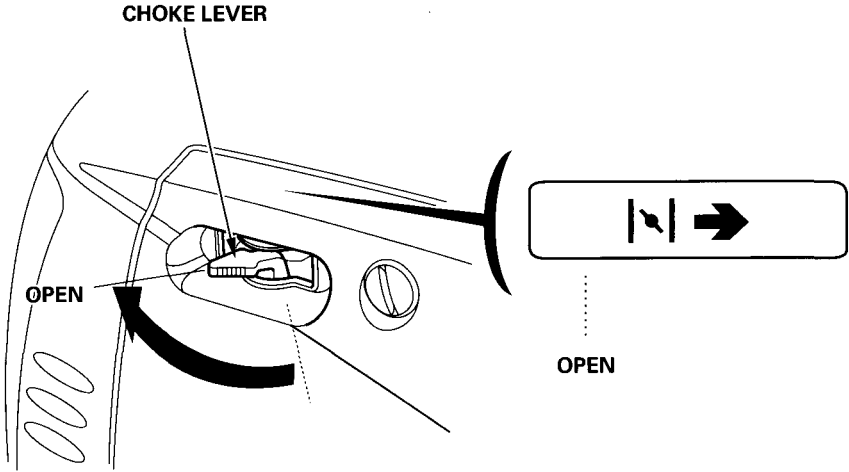

NOTE:

If the engine stops and will not restart, check the engine oil level (see page 13) before troubleshooting in other areas.

• Carburetor Modification for High Altitude Operation

At high altitude, the standard carburetor air-fuel mixture will be too rich. Performance will decrease, and fuel consumption will increase. A very rich mixture will also foul the spark plug and cause hard starting. Operation at an altitude that differs from that at which this engine was certified, for extended periods of time, may increase emissions.

High altitude performance can be improved by specific modifications to the carburetor. If you always operate your generator at altitudes above 1,500 meters (5,000 feet), have your authorized Honda servicing dealer perform this carburetor modification. This engine, when operated at high altitude with the carburetor modifications for high altitude use, will meet each emission standard throughout its useful life.

Even with carburetor modification, engine horsepower will decrease about 3.5% for each 300-meter (1,000-foot) increase in altitude. The effect of altitude on horsepower will be greater than this if no carburetor modification is made.

CAUTION:

When the carburetor has been modified for high altitude operation, the air-fuel mixture will be too lean for low altitude use. Operation at altitudes below 1,500 meters (5,000 feet) with a modified carburetor may cause the engine to overheat and result in serious engine damage. For use at low altitudes, have your servicing dealer return the carburetor to original factory specifications.

6. GENERATOR USE

Be sure to ground the generator when the connected equipment is grounded.

▲WARNING

Connections for standby power to a building's electrical system must be made by a qualified electrician and must comply with all applicable laws and electrical codes. Improper connections can allow electrical current from the generator to backfeed into the utility lines. Such backfeed may electrocute utility company workers or others who contact the lines during a power outage, and when utility power is restored, the generator may explode, burn, or cause fires in the building's electrical system.

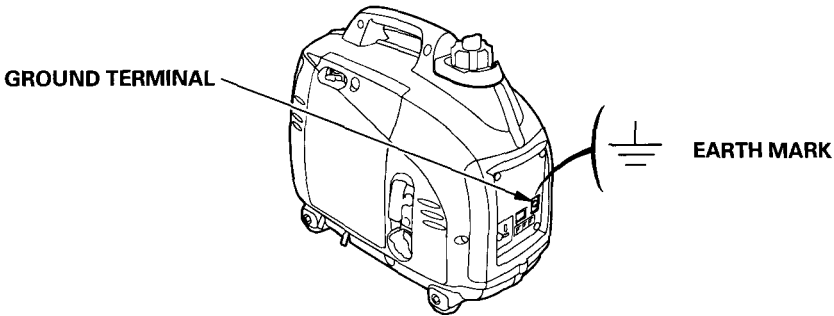

CAUTION:

- For continuous operation, do not exceed the rated power (see page 48).
In either case, the total wattage of all appliances connected must be considered.
- Do not exceed the current limit specified for any one receptacle.
- Do not connect the generator to a household circuit. This could cause the damage to the generator or to electrical appliances in the house.
- Do not modify or use the generator for other purposes than it is intended for. Also observe the following when using the generator.
 - Do not connect an extension to the exhaust pipe.
- When an extension cable is required, be sure to use a tough rubber sheathed flexible cable (IEC 245 or equivalent).
- Limit length of extension cables; 60 m for cables of 1.5 mm² and 100 m for cables of 2.5 mm². Long extension cables will lower usable power due to resistance in the extension cable.
- Keep the generator away from other electric cables or wires such as commercial power supply lines.

NOTE:

- The DC receptacle can be used while the AC power is in use. If you use both at the same time, be sure not to exceed the total power for AC and DC. (See page 48).
- Most appliance motors require more than their rated wattage for startup.

AC applications

1. Start the engine and make sure the output indicator (green) comes on.
2. Confirm that the appliance to be used is switched off, and plug in the appliance.

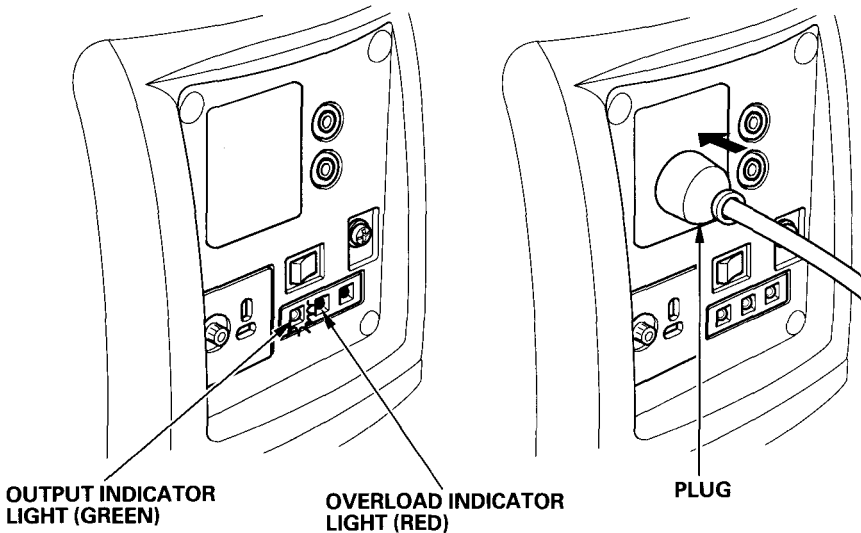

CAUTION:

- Substantial overloading that continuously lights the overload indicator light (red) may damage the generator. Marginal overloading that temporarily lights the overload indicator light (red) may shorten the service life of the generator.
- Be sure that all appliances are in good working order before connecting them to the generator. If an appliance begins to operate abnormally, becomes sluggish, or stops suddenly, turn off the generator engine switch immediately. Then disconnect the appliance, and examine it for signs of malfunction.

Output and Overload Indicators

The Output indicator (green) will remain ON during normal operating conditions.

If the generator is overloaded (in excess of 1.0 kVA), or if there is a short in the connected appliance, the output indicator light (green) will go OFF, the overload indicator light (red) will go ON and current to the connected appliance will be shut off.

Stop the engine if the Overload indicator (red) comes ON and investigate the overload source.

- Before connecting an appliance to the generator, check that it is in good order, and that its electrical rating does not exceed that of the generator. Then connect the power cord of the appliance, and start the engine.

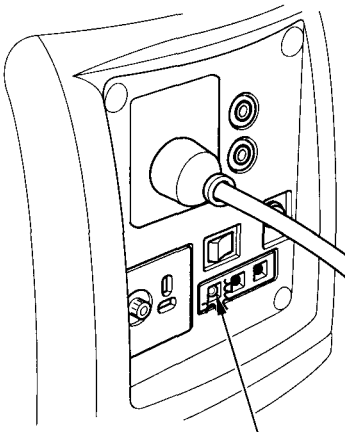

OUTPUT INDICATOR LIGHT
(GREEN)

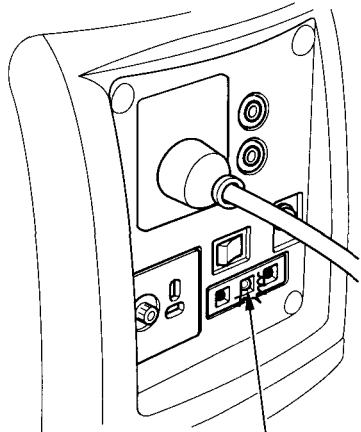

OUTPUT INDICATOR LIGHT
(RED)

NOTE:

When an electric motor is started, both the Overload indicator (red) and the Output indicator (green) may go on simultaneously. This is normal if the Overload indicator (red) goes off after about five (5) seconds. If the Overload indicator (red) stays on, consult your Honda generator dealer.

Parallel operation

Please read the item "GENERATOR USE" before connecting any equipment to be used.

A max output of 2.0 kVA can be obtained by using two units (EU10i) in parallel operation (connection in parallel).

There are the terminals into which the special cable is inserted for parallel operation.

Always use only the special cable for parallel operation (sold separately).

Please order the special cable from the shop where you purchased the unit or from a service station.

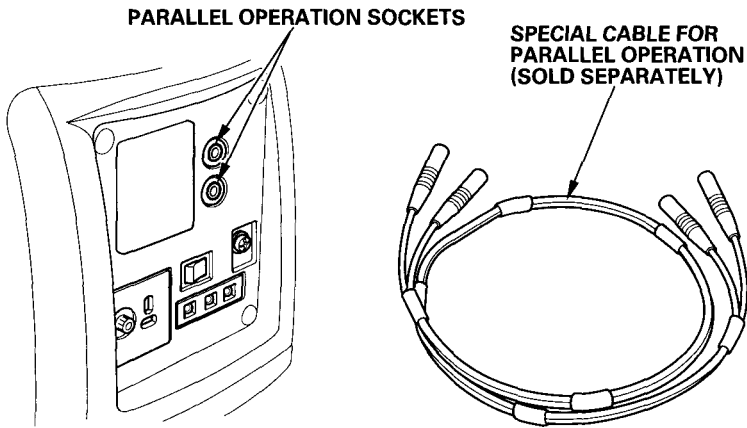

CAUTION:

Limit operation requiring maximum power to 30 minutes.

For continuous operation, do not exceed the rated power.

In either case, the total wattage of all appliances connected must be considered.

Maximum power in parallel operation is:

2.0 kVA

Rated power in parallel operation is:

1.8 kVA

▲WARNING

- Never connect the different generator models and types.
- Never connect a cable other than the special cable for parallel operation.
- Connect and remove the special cable for parallel operation with the engine stopped.
- For single operation, the special cable for parallel operation must be removed.

NOTE:

- Depending on the equipment to be used, an overload may be caused, the overload indicator light (red) may light, and it may become impossible to take out any more electric power.
- Motors generally require two to three times of their power consumption for starting.

1. Connect the special cable for parallel operation to the two generators.

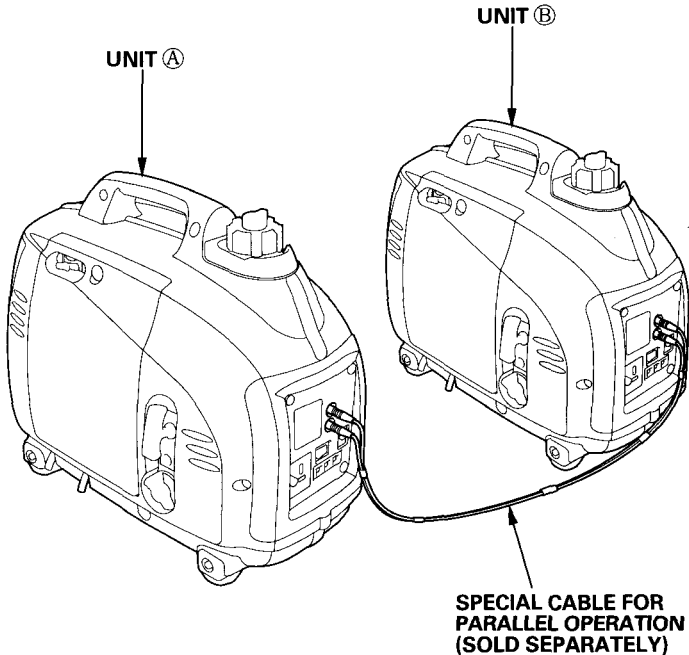

2. Be sure to ground the generator when the connected equipment is grounded.

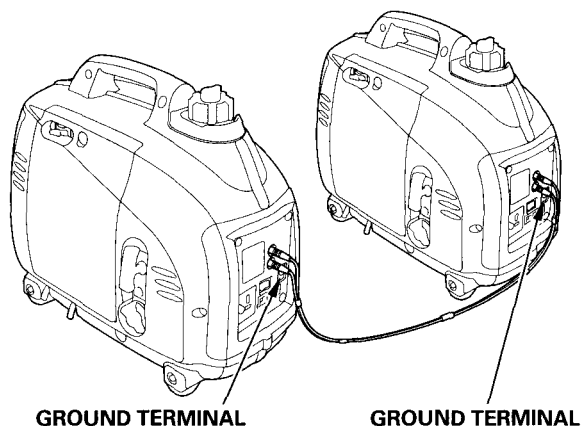

3. Start each engine according to "STARTING THE ENGINE".
- When the output indicator light (green) does not light and the overload indicator light (red) lights instead, set the engine switch to STOP, stop the engine once, and then start the engine again.
4. Confirm that the equipment to be used is switched off, and insert the plug of the equipment to be used into the AC receptacle of unit ① or unit ②.

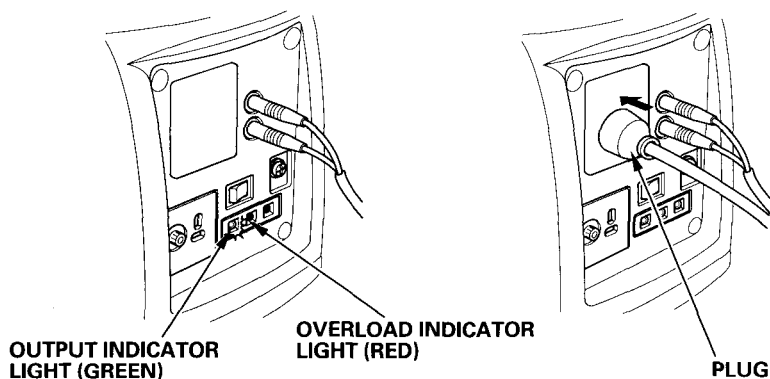

CAUTION:

Confirm that the use equipment to be connected is switched off. When the equipment to be used is switched on, it will operate suddenly, and injuries or accidents may be caused.

-
6. Switch on the equipment to be used.
The output indicator light (green) will light.

In case of normal operation

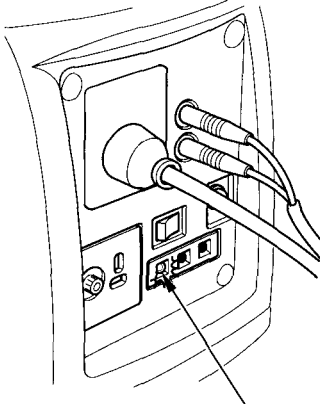

OUTPUT INDICATOR LIGHT
(GREEN)

In case of overload operation or short-circuit

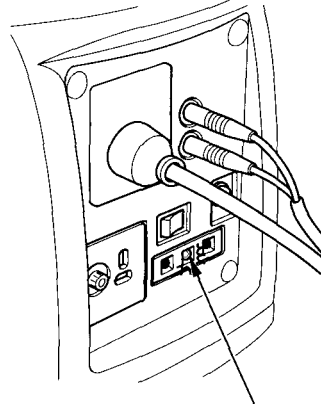

OVERLOAD INDICATOR LIGHT
(RED)

- In case of overload operation (refer to page 26) or when trouble occurs for the equipment being used, the output indicator light (green) will go out, the overload indicator light (red) will light continuously, and no power will be put out. At this time, the engine will not stop, so that the engine must be stopped by setting the respective engine switch to STOP.

NOTE:

- When equipment requiring a large starting power, like a motor etc., is used, the overload indicator light (red) and the output indicator light (green) may light together for a short time (about 4 sec), but this is no abnormality. After start of the equipment, the overload indicator light (red) will go out and the output indicator light (green) will stay lit.
 - When the operation of one generator is to be stopped after start of the equipment, the special cable for parallel operation also must be removed at the same time.
7. When electric power is to be taken again from the generator, switch off the equipment to be used and remove the plug from the AC receptacle. Confirm that the equipment and the connection are normal and that not too much power is to be taken, and then start the engine.

DC Application

The DC receptacle may be used for charging 12 volt automotive-type batteries only.

NOTE:

- In DC operation, turn the eco throttle switch to the OFF position.
1. Connect the charging cable to the DC receptacle of the generator and then to the battery terminals.

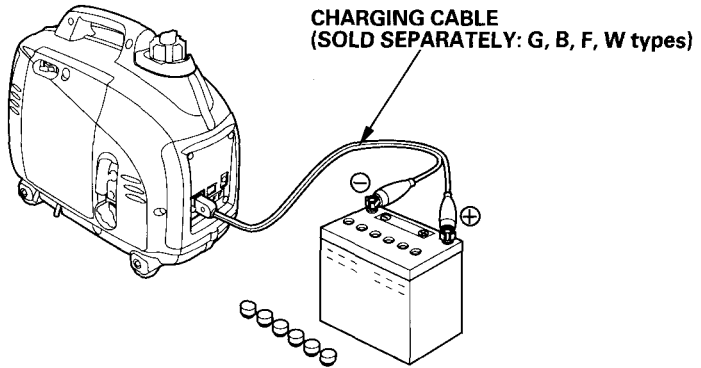

▲WARNING

- To prevent the possibility of creating a spark near the battery, connect charging cable first to the generator, then to the battery. Disconnect cable first at the battery.
- Before connecting charging cable to a battery that is installed in a vehicle, disconnect the vehicle's battery cable. Reconnect the vehicle's battery cable after the charging cables are removed. This procedure will prevent the possibility of a short circuit and sparks if you make accidental contact between a battery terminal and the vehicle's frame or body.

CAUTION:

- Do not attempt to start an automobile engine with the generator still connected to the battery. The generator may be damaged.
- Connect the positive battery terminal to the positive charging cord. Do not reverse the charging cables, or serious damage to the generator and/or battery may occur.

▲WARNING

- **Batteries produce explosive gases:** If ignited, an explosion can cause serious injury or blindness. Provide adequate ventilation when charging.
- **CHEMICAL HAZARD:** Battery electrolyte contains sulfuric acid. Contact with eyes or skin, even through clothing, may cause severe burns. Wear a faceshield and protective clothing.
- **Keep flames and sparks away, and do not smoke in the area.**
ANTIDOTE: If electrolyte gets into your eyes, flush thoroughly with warm water for at least 15 minutes and call a physician immediately.
- **POISON:** Electrolyte is poison.
ANTIDOTE
 - **External:** Flush thoroughly with water.
 - **Internal:** Drink large quantities of water or milk.
Follow with milk of magnesia or vegetable oil, and call a physician immediately.
- **KEEP OUT OF REACH OF CHILDREN.**

2. Start the engine.

NOTE:

- The DC receptacle can be used while the AC power is in use.
- The C type cannot be used for both AC and DC simultaneously.
- An overload DC circuit will trip the DC circuit protector (push button comes out).
If this happens, wait a few minutes before pushing in the circuit protector to resume operation.

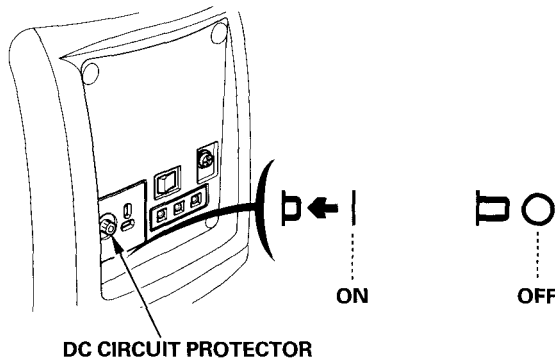

Oil alert system

The Oil Alert system is designed to prevent engine damage caused by an insufficient amount of oil in the crankcase. Before the oil level in the crankcase falls below a safe limit, the Oil Alert system will automatically shut down the engine (the engine switch will remain in the ON position).

If the Oil Alert system shuts down the engine, the Oil Alert indicator (red) will come on when you operate the starter, and the engine will not run. If this occurs, check the engine oil level (see page 13).

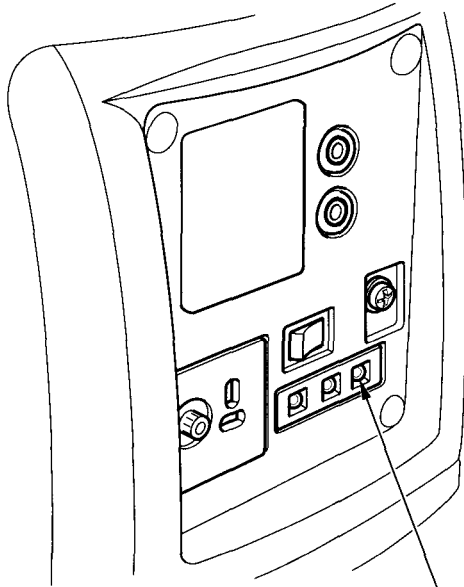

**OIL ALERT INDICATOR
LIGHT (RED)**

7. STOPPING THE ENGINE

To stop the engine in an emergency, turn the engine switch to the OFF position.

IN NORMAL USE:

1. Switch off the connected equipment and pull the inserted plug.

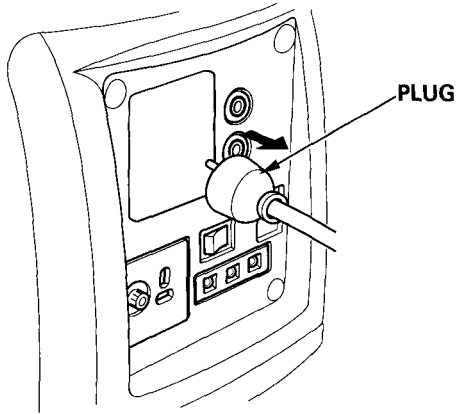

2. Turn the engine switch to the OFF position.

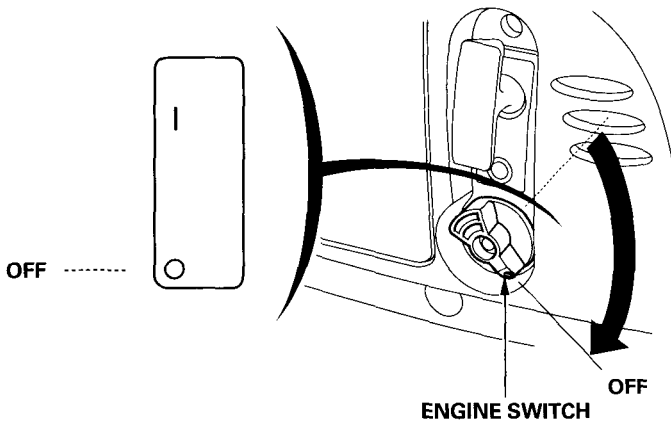

3. Turn the fuel cap vent lever fully counterclockwise to the "OFF" position.

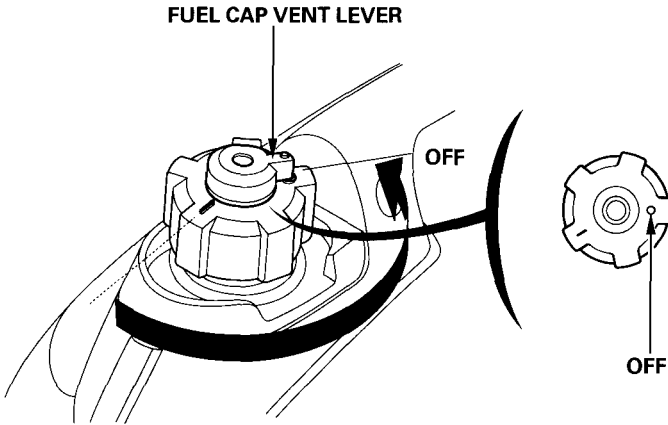

CAUTION:

Be sure the fuel cap vent lever and the engine switch are "OFF" when stopping, transporting and/or storing the generator.

4. When parallel operation has been executed, pull the special cable for parallel operation.

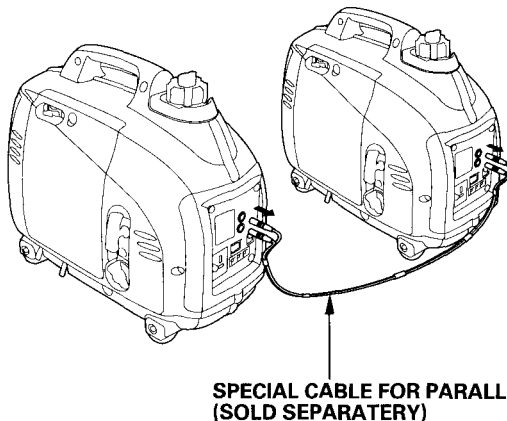

8. MAINTENANCE

The purpose of the maintenance and adjustment schedule is to keep the generator in the best operating condition. Inspect or service as scheduled in the table below.

▲WARNING

Shut off the engine before performing any maintenance. If the engine must be run, make sure the area is well ventilated. The exhaust contains poisonous carbon monoxide gas.

CAUTION:

Use genuine Honda parts or their equivalent. The use of replacement parts which are not of equivalent quality may damage the generator.

Maintenance Schedule

REGULAR SERVICE PERIOD (3)		Each use	First month or 10 hrs.	Every 3 months or 50 hrs.	Every 6 months or 100 hrs.	Every 2 years or 300 hrs.
Item	Performed at every indicated month or operating hour interval, whichever comes first.					
Engine oil	Check level	○				
	Change		○		○	
Air cleaner	Check	○				
	Clean			○ (1)		
Spark plug	Check-adjust				○	
	Replace					○
Spark arrester	Clean				○	
Valve Clearance	Check-adjust					○ (2)
Combustion chamber	Clean	After every 300 hrs (2)				
Fuel tank & filter	Clean	Every year (2)				
Fuel line	Check	Every 2 years (Replace if necessary) (2)				

- NOTE:**
- (1) Service more frequently when used in dusty areas.
 - (2) These items should be serviced by your servicing dealer, unless you have the proper tools and are mechanically proficient. Refer to Honda shop manual for service procedures.
 - (3) For commercial use, log hours of operation to determine proper maintenance intervals.

1. CHANGING OIL

Drain the oil while the engine is still warm to assure rapid and complete draining.

CAUTION:

Make sure to turn the engine switch and the fuel cap vent lever OFF before draining.

1. Loosen the cover screw and remove the left side maintenance cover.
2. Remove the oil filler cap.
3. Drain dirty oil into a container thoroughly.
4. Refill with the recommended oil (see page 13) and check the oil level.
5. Reinstall the left side maintenance cover and tighten the cover screw securely.

ENGINE OIL CAPACITY: 0.25 ℓ (0.26 US qt , 0.22 Imp qt)

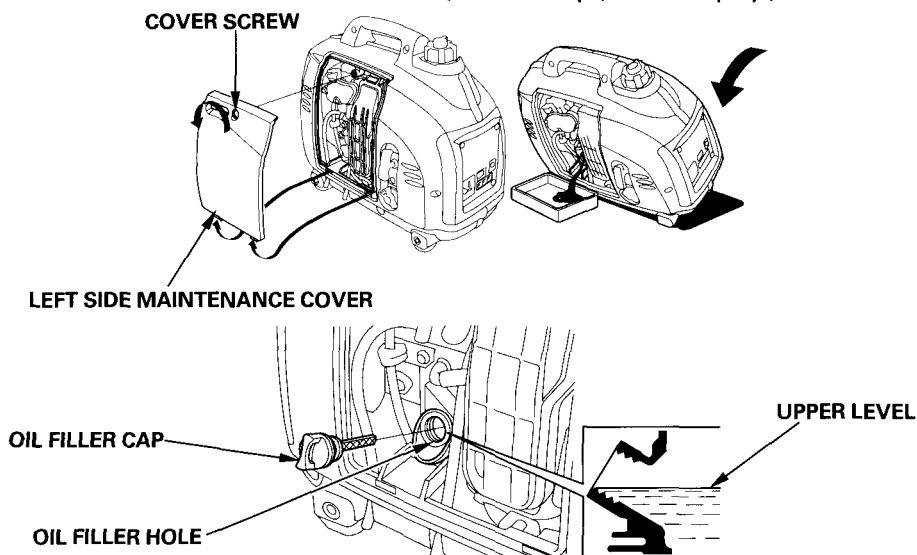

Wash your hands with soap and water after handling used oil.

NOTE:

Please dispose of used motor oil in a manner that is compatible with the environment. We suggest you take it in a sealed container to your local service station for reclamation. Do not throw it in the trash or pour it on the ground.

2. AIR CLEANER SERVICE

A dirty air cleaner will restrict air flow to the carburetor. To prevent carburetor malfunction, service the air cleaner regularly. Service more frequently when operating the generator in extremely dusty areas.

▲WARNING

Do not use gasoline or low flash point solvents for cleaning. They are flammable and explosive under certain conditions.

CAUTION:

Never run the generator without the air cleaner. Rapid engine wear may result.

1. Loosen the cover screw and remove the left side maintenance cover.
2. Press the latch tab on the top of the air cleaner body, and remove the air cleaner cover.
3. Wash the element in a non-flammable or high flash point solvent and dry it thoroughly.
4. Soak the element in clean engine oil and squeeze out the excess oil.
5. Reinstall the air cleaner element and the cover.
6. Reinstall the air cleaner cover by inserting the lower tabs, and the latch tab.
7. Reinstall the left side maintenance cover and tighten the cover screw securely.

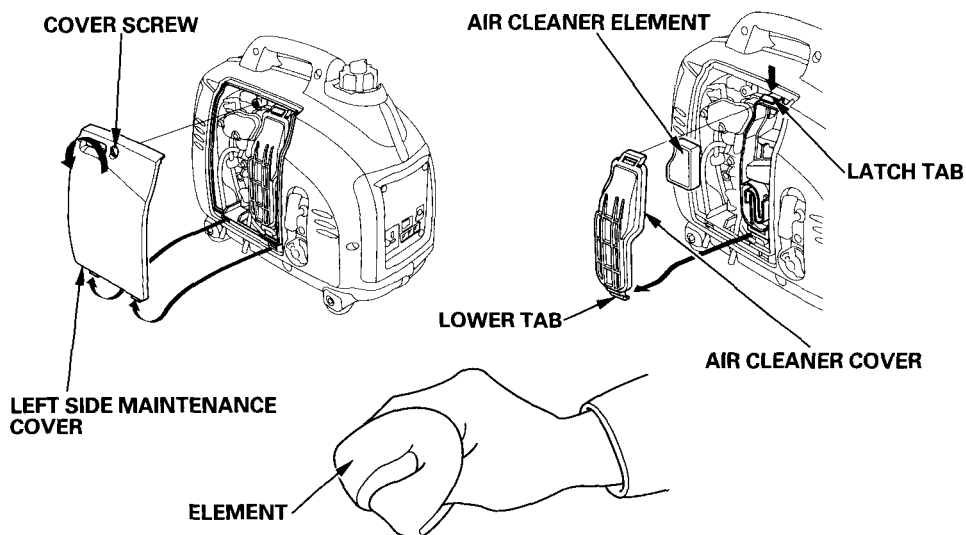

3. SPARK PLUG SERVICE

**RECOMMENDED SPARK PLUG: CR4HSB (NGK)
U14FSR-UB (DENSO)**

To ensure proper engine operation, the spark plug must be properly gapped and free of deposits.

1. Remove the spark plug maintenance cover.

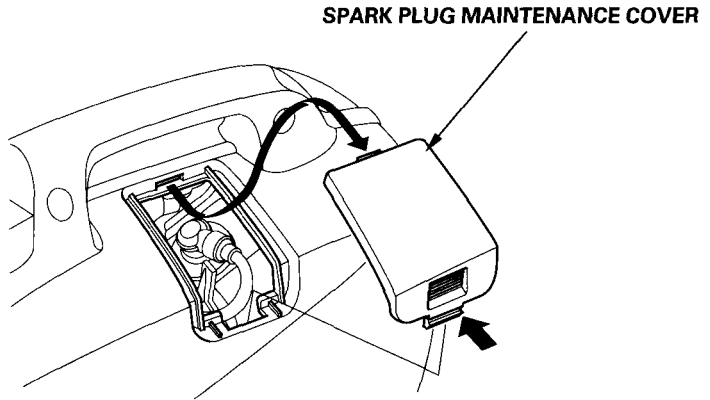

2. Remove the spark plug cap.
3. Clean any dirt from around the spark plug base.
4. Use a spark plug wrench to remove the spark plug.

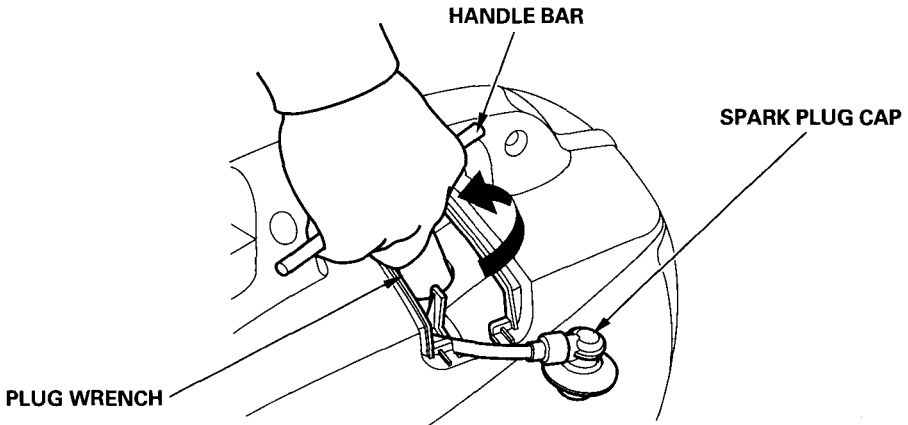

-
5. Visually inspect the spark plug. Discard it if the insulator is cracked or chipped. Clean the spark plug with a wire brush if it is to be reused.
 6. Measure the plug gap with a feeler gauge. Correct as necessary by carefully bending the side electrode. The gap should be:
0.60–0.70 mm (0.024–0.028 in)

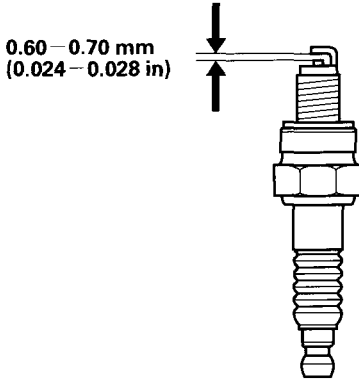

7. Install the spark plug carefully, by hand, to avoid cross-threading.
8. After a new spark plug has been seated by hand, it should be tightened 1/2 turn with a wrench to compress its washer. If a used plug is being reinstalled, it should only require 1/8 to 1/4 turn after being seated.
9. Reinstall the spark plug cap on the spark plug securely.
10. Reinstall the spark plug maintenance cover.

CAUTION:

- The spark plug must be securely tightened. An improperly tightened plug can become very hot and possibly damage the generator.
- Never use a spark plug with an improper heat range.

4. SPARK ARRESTER MAINTENANCE (Equipped type)

⚠ WARNING

If the generator has been running, the muffler will be very hot. Allow it to cool before proceeding.

CAUTION:

The spark arrester must be serviced every 100 hours to maintain its efficiency.

1. Remove the four 5 mm screws, and remove the muffler protector.

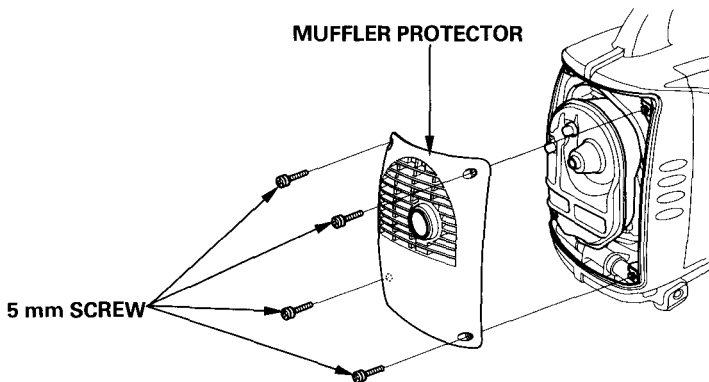

2. Remove the three 6 mm bolts, and remove the muffler, the spark arrester and the muffler gasket.

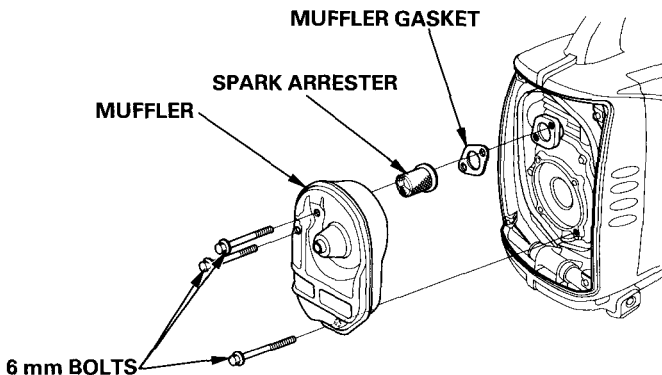

-
3. Use a brush to remove carbon deposits from the spark arrester screen.
Inspect the spark arrester screen for holes or tears. Replace if necessary.



4. Check the muffler gasket; replace if damaged.
Reinstall the muffler gasket, the spark arrester, the muffler and the muffler protector in the reverse order of removal.

9. TRANSPORTING/STORAGE

To prevent fuel spillage when transporting or during temporary storage, the generator should be secured upright in its normal operating position, with the engine switch OFF.

The fuel cap vent lever is turned fully counterclockwise to the "OFF" position.

▲WARNING

When transporting the generator:

- Do not overfill the tank (there should be no fuel in the filler neck).
- Do not operate the generator while it is on a vehicle. Take the generator off the vehicle and use it in a well ventilated place.
- Avoid a place exposed to direct sunlight when putting the generator on a vehicle. If the generator is left in an enclosed vehicle for many hours, high temperature inside the vehicle could cause fuel to vaporize resulting in a possible explosion.
- Do not drive on a rough road for an extended period with the generator on board. If you must transport the generator on a rough road, drain the fuel from the generator beforehand.

Before storing the unit for an extended period:

1. Be sure the storage area is free of excessive humidity and dust.
2. Drain the fuel.

▲WARNING

Gasoline is extremely flammable and is explosive under certain conditions. Perform this task in a well ventilated area with the engine stopped. Do not smoke or allow flames or sparks in the area during this procedure.

- a. Drain all gasoline from the fuel tank into an approved gasoline container.

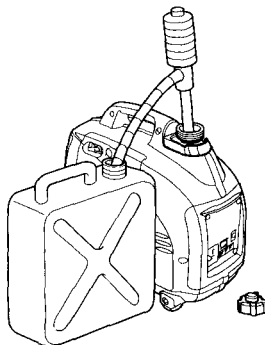

-
- b. Turn the engine switch ON, and loosen the carburetor drain screw and drain the gasoline from the carburetor into a suitable container.
 - c. With the drain screw loosened remove the spark plug cap, and pull the starter grip 3 to 4 times to drain the gasoline from the fuel pump.
 - d. Turn the engine switch to the OFF position, and tighten the drain screw securely.
 - e. Reinstall the spark plug cap on the spark plug securely.

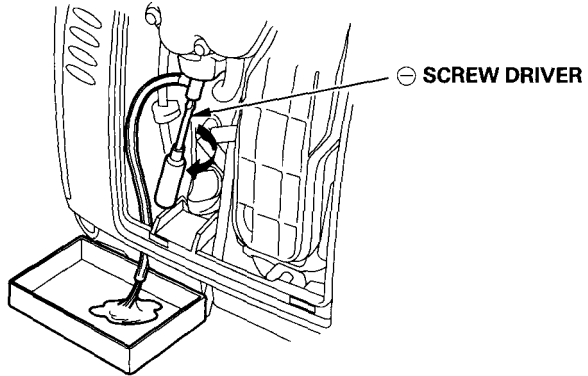

3. Change the engine oil.
4. Remove the spark plug and pour about a tablespoon of clean engine oil into the cylinder. Crank the engine several revolutions to distribute the oil, then reinstall the spark plug.
5. Slowly pull the starter grip until resistance is felt. At this point, the piston is coming up on its compression stroke and both the intake and exhaust valves are closed. Storing the engine in this position will help to protect it from internal corrosion.

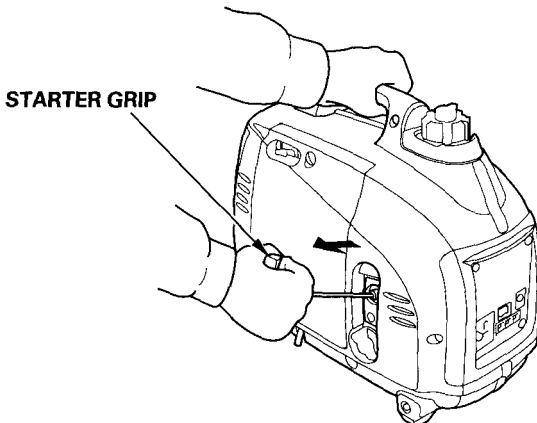

10. TROUBLESHOOTING

When the engine will not start:

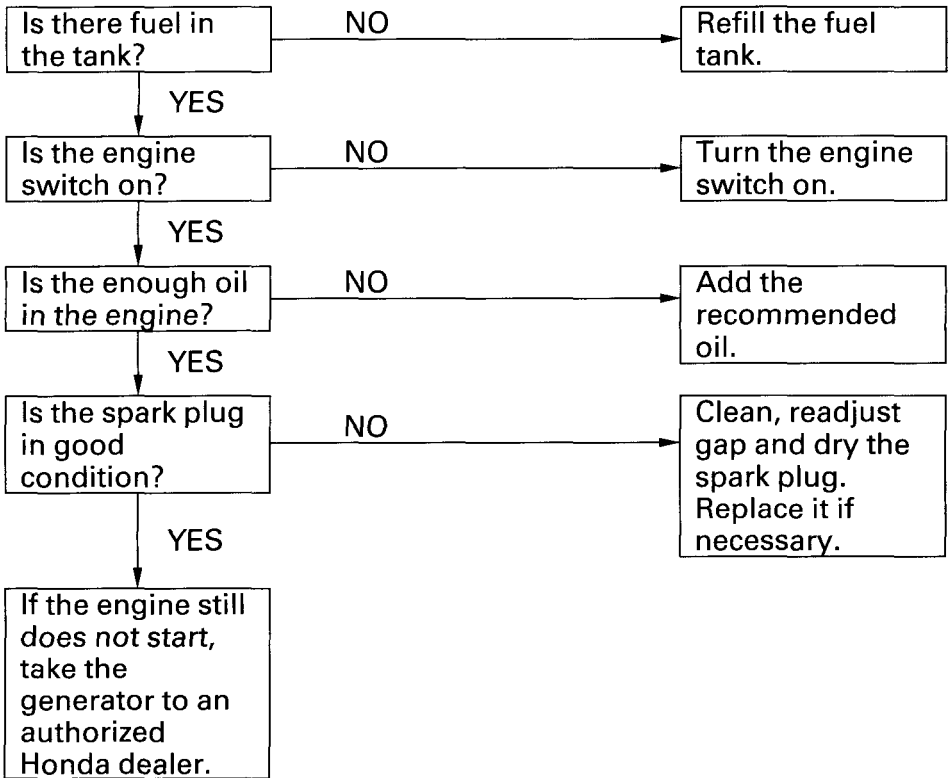

Appliance does not operate:

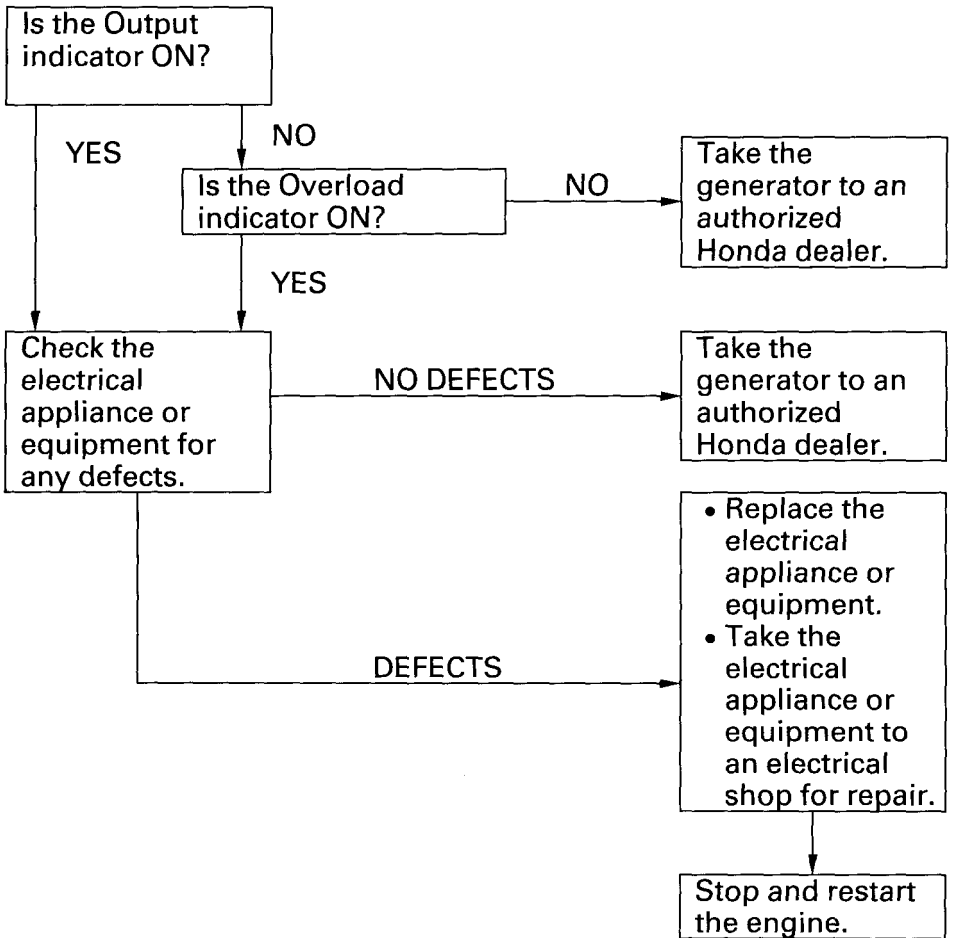

No electricity at the DC receptacle:

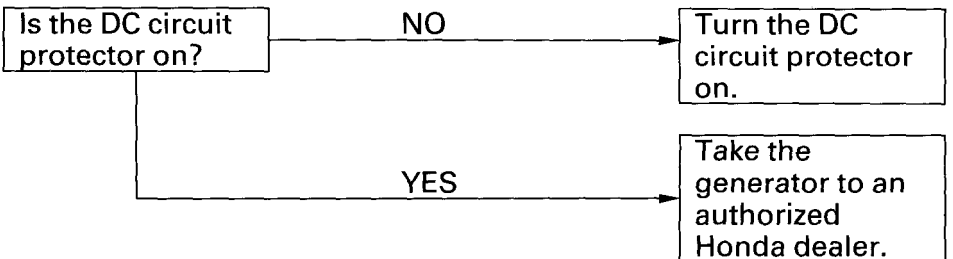

11. SPECIFICATIONS

Dimensions and Weight

Model	EU10i
Description code	EZGA
Length	451 mm (17.8 in)
Width	242 mm (9.5 in)
Height	379 mm (14.9 in)
Dry weight	13 kg (29 lbs)

Engine

Model	GXH50
Engine type	4-stroke, overhead valve, single cylinder
Displacement	49.4 cm ³ (3.01 cu-in)
Bore × Stroke	41.8 × 36.0 mm (1.64 in × 1.42 in)
Compression ratio	8.0:1
Engine speed	5,500 rpm (with eco throttle switch OFF)
Cooling system	Forced air
Ignition system	Full transistor
Oil capacity	0.25 l (0.26 US qt, 0.22 Imp qt)
Fuel tank capacity	2.1 l (0.55 US gal, 0.46 Imp gal)
Spark plug	CR4HSB (NGK) U14FSR-UB (DENSO)

Generator

Model		EU10i	
Type		G, GW, B, F, W	U
AC output	Rated voltage (V)	230	240
	Rated frequency (Hz)	50	50
	Rated Ampere (A)	3.9	3.8
	Rated Output (VA)	900	
	Max Output (VA)	1,000	
DC rated output		Only for charging 12 V automotive batteries. 12 V, 8 A	

Noise

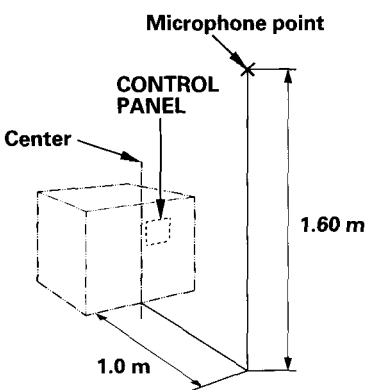
Model		EU10i	
Type		G, GW, B, F, W	U
Sound pressure level (LpA) According to 98/37/EC		72 dB	_____
			
Guaranteed sound power level (LWA) Tested by 2000/14/EC		87 dB	_____

NOTE:

Specifications are subject to change without notice.

12. WIRING DIAGRAM

AC, NF	AC Noise Filter
ACOR	AC Output Receptacle
Ca	Capacitor
Cot	Composite Socket
CPB	Control Panel Block
DC, D	DC Diode
DC, NF	DC Noise Filter
DCOR	DC Output Receptacle
DC, W	DC Winding
EcoSw	Eco throttle switch
EgB	Engine Block
EgG	Engine Ground
ESw	Engine Switch
ExW	Exciter Winding
FrB	Frame Block
FrG	Frame Ground
GeB	Generator Block
GT	Ground Terminal
IgC	Ignition Coil
IU	Inverter Unit
MW	Main Winding
OAL	Oil Alert Indicator
OI	Overload Indicator
OLSw	Oil Level Switch
PC	Pulser Coil
PL	Output Indicator
SP	Spark Plug
SpU	Spark Unit
StpM	Stepping Motor
SW	Sub Winding

Bl	BLACK
Y	YELLOW
Bu	BLUE
G	GREEN
R	RED
W	WHITE
Br	BROWN
Lg	LIGHT GREEN
Gr	GRAY
Lb	LIGHT BLUE
O	ORANGE
P	PINK

ENGINE SWITCH

	G	Bl
OFF	<input type="radio"/>	<input type="radio"/>
ON		

ECOTHROTTLE SWITCH

	R/W	R/Y	ECO
ON	<input type="radio"/>	<input type="radio"/>	OFF
OFF			ON

G, GW, B, F, W type

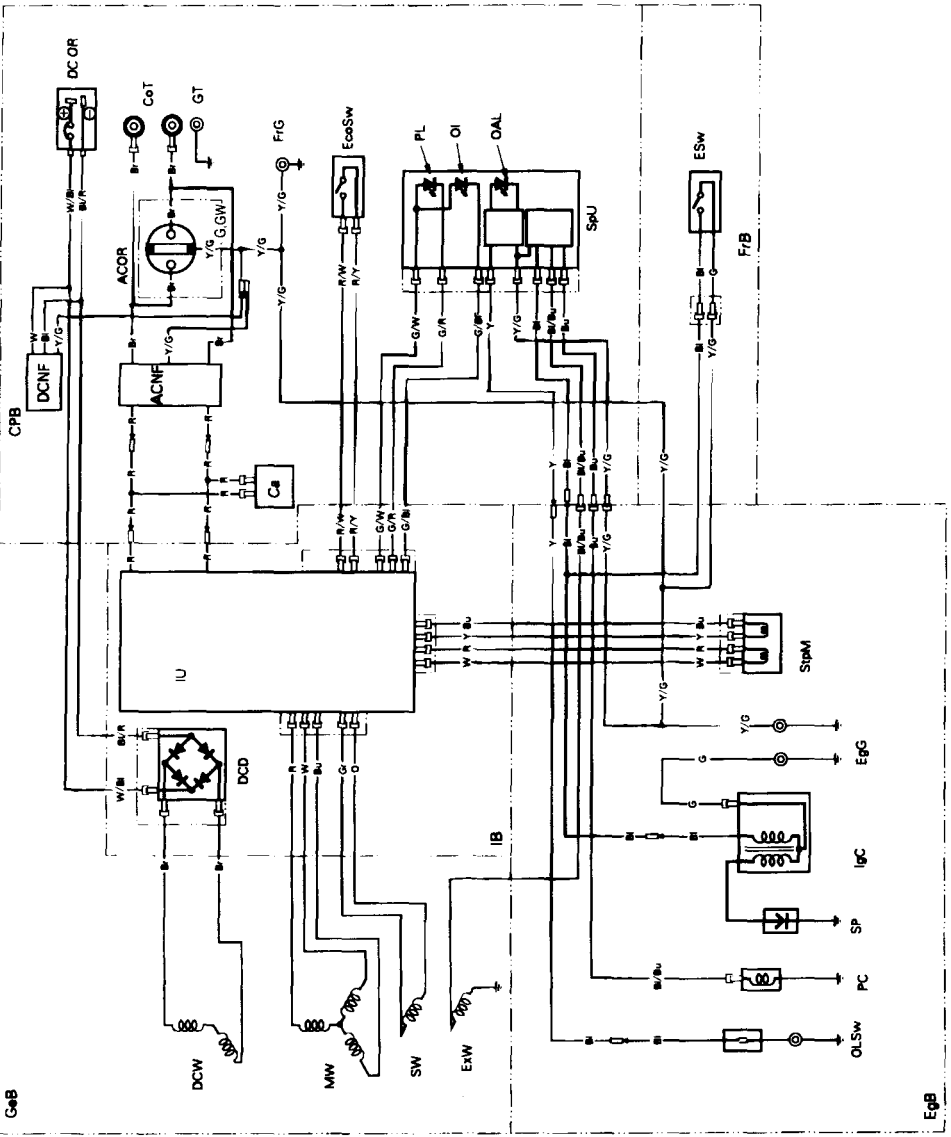
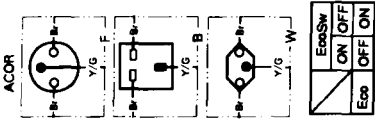





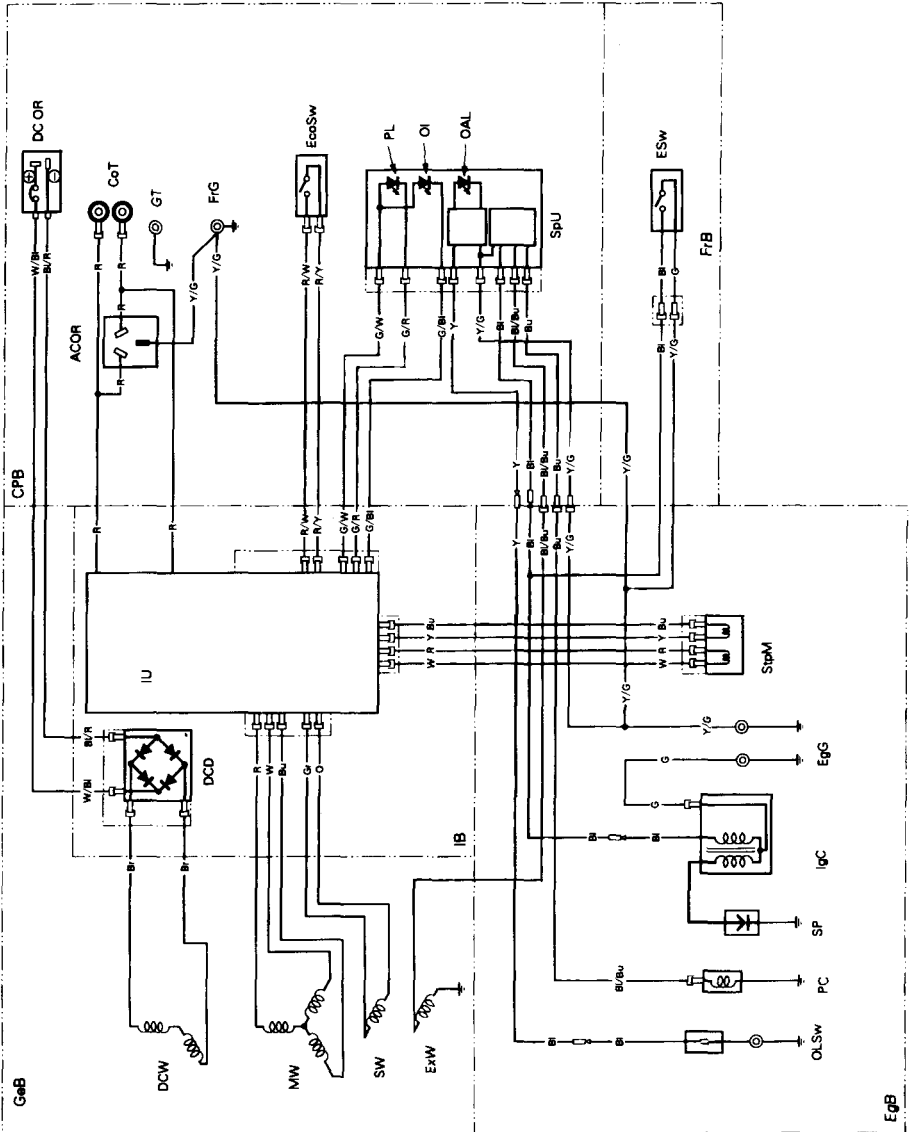



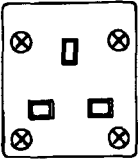

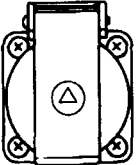
U type

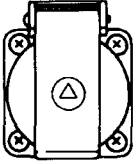
	EcoSw	ON	OFF
	Eco	OFF	ON

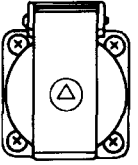

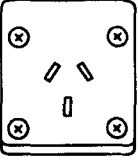
RECEPTACLE

Shape		Type
		B
		W
		F
		G, GW
		U

13. MAJOR Honda DISTRIBUTOR ADDRESSES

For European

NAME OF FIRM (COMPANY)	ADDRESS	TEL: FAX:
Honda (U.K.) Limited	470 London Road, Slough, Berkshire, SL38QY, United Kingdom	Tel: 01753-590-590 Fax: 01753-590-000
Honda Europe Power Equipment S.A.	Pole 45 Rue des Chataigniers 45140 Ormes France	Tel: 2-38-65-06-00 Fax: 2-38-65-06-02
Honda Motor Europe (North) GmbH.	Spredlinger, Landstraße 166 D-63069 Offenbach/Main Germany	Tel: 069-83-09-0 Fax: 069-83-09-519
Honda Belgium H.V.	Wijngaardveld 1, 9300 Aalst Belgium	Tel: 053-725-111 Fax: 053-725-100
Honda Italia Industriale S.P.A.	Via della Cecchignola, 5/7 00143 ROMA	Tel: 06-54928-1 Fax: 06-54928-400
Honda (Suisse) S.A.	Route des Moulières 10 Case postale Ch 1214 Vernier-Geneve, Switzerland	Tel: 022-341-22-00 Fax: 022-341-09-72
Honda Nederland B.V.	Capronilaan 1 1119 NN Schiphol-Rijk Netherlands	Tel: 020-7070000 Fax: 020-7070001
Honda Austria G.M.B.H.	Honda Strasse 1 A-2351 Wiener Neudorf Austria	Tel: 223-66-900 Fax: 223-66-4130
Honda Power Equipment Sweden AB	Västkustvägen 17 202 15 Malmö, Sweden	Tel: 040-600 23 00 Fax: 040-600 23 19
Honda Produtos De Força, Portugal, S.A.	Lugar da Abrunheira S. Pedro de Penaferrim 2710 Sintra, Portugal	Tel: 351-1-9150374 Fax: 351-1-9111021
Berema A/S	Berghagan 5, Langhus Box 454, 1401 Ski Norway	Tel: 64-86-05-00 Fax: 64-86-05-49

For European (continued)

NAME OF FIRM (COMPANY)	ADDRESS	TEL: FAX:
OY Brandt AB	Tuupakantie 4 SF-01740, Vantaa Finland	Tel: 90-895-501 Fax: 90-878-5276
TIMA PRODUCTS A/S	Tårnfalkevej 16, Postboks 511 DK 2650 Hvidovre Denmark	Tel: 31-49-17-00 Fax: 36-77-16-30
Greens	Polig. Industrial Congost 08530, La Garriga (Barcelona), Spain	Tel: 93-871-84-50 Fax: 93-871-81-80
Automocion Canarias S.A. (AUCASA)	Apartado de Correos, num 206 Santa Cruz de Tenerife Canary Island	Tel: 922-61-13-50 Fax: 922-61-13-44
The Associated Motors Company Ltd.	148, Rue D'Argens, Msida Malta	Tel: 356-333001 Fax: 356-340473
Two Wheels Ltd.	Crosslands Business Park, Ballymount Road, Dublin 12, Ireland	Tel: 4602111 Fax: 4566539
General Automotive Co., S.A.	P.O. Box 1200, 101 73 Athens Greece	Tel: 346-5321 Fax: 346-7329
BG Technik s.r.o	Radlická 117/520 158 01 Praha 5 Czech Republic	Tel: 2-5694 573 Fax: 2-5694 571
Aries Power Equipment Ltd.	01-493 Warszawa, ul Wroclawska 25a Poland	Tel: 22-685 17 06 Fax: 22-685 16 03
MO. TOR. PEDO Ltd.	2040 Buda-rs, Kamaraerdei-t 3. Hungary	Tel: 23-444-971 Fax: 23-444-972
MDL Motors	140 Dzirnavu Street Riga LV 1050 Latvia	Tel: 371-7211071 Fax: 371-7821028
UAB "Wood Stock"	Savanoriu 174 a, LT 2600 Lithuania	Tel: 370-61-606896 Fax: 370-52-132756
Honda Slovakia spol. s r.o.	Polus Millennium Tower Vajnorska ul. 100/A 831 03 Bratislava 3 Slovak Republic	Tel: 42-1-2-4444-1156 Fax: 42-1-2-4444-1150
AS Domzale Moto Center D.O.O.	Blantnica 3a, 1236 Trzin Slovenia	Tel: 386-1-562-2242 Fax: 386-1-562-3705

For Australian

NAME OF FIRM (COMPANY)	ADDRESS	TEL: FAX:
Honda Australia Motorcycle and Power Equipment Pty. Ltd	1954-1956 Hume Highway Campbellfield Victoria 3061	Tel: (03) 9270 1111 Fax: (03) 9270 1133

HONDA

The Power of Dreams

36ZT3609
00X36-ZT3-6091

© Honda Motor Co., Ltd. 2002
EU1 英 仏 独 西 日 (HC) 2000.2007.06
Printed in Japan